

Baydur® GS

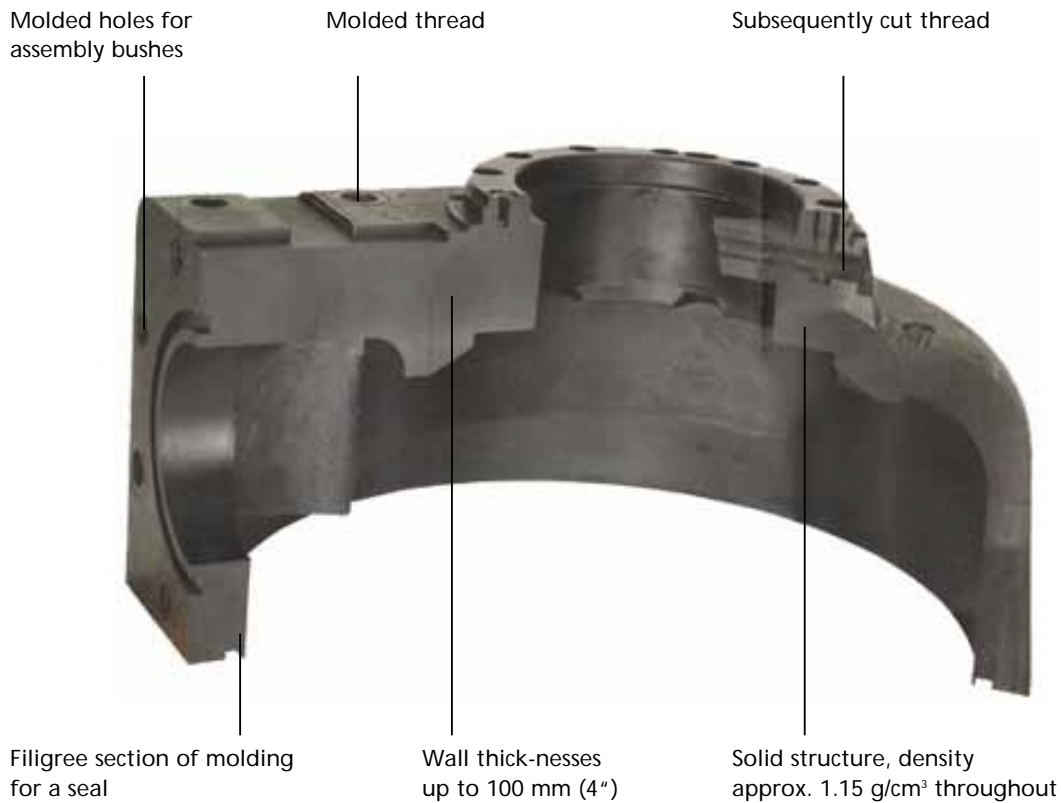

High impact strength, rigidity and heat deformation temperature

High chemical resistance and rot resistance

Wall thicknesses from 4 to 100 mm (0.2 to 4 Inch), short cure times even with high wall thicknesses, due to the lack of internal gas pressure

Cost-efficient production of large parts through a low cavity pressure

Inexpensive aluminum molds requiring only a short lead time

Prototype and small series can be produced in simple molds (cast resin molds)

Different raw material systems for different applications

Surfaces:
 - natural, colored black or brown
 - with structural coating

CFC-free

Recyclable

Baydur® GS

Technical Data

Product			Baydur® GS*
Property	Unit	Standard	
Density	kg/m ³	DIN 53432	1200
Flexural strength	MPa	DIN 53432	72
Modulus of elasticity in bending	MPa	DIN 53432	1500
Tensile strength	MPa	DIN 53432	46
Modulus of elasticity in tension	MPa	DIN 53432	1450
Elongation at break	%	DIN 53432	21
Tensile strain at break	%	DIN 53432	35
Impact strength	kJ/m ²	DIN 53432	85
Notched impact strength	kJ/m ²	DIN 53432	8
Hardness	Shore D	DIN 53432	76
High-temperature behavior under flexural load	°C	DIN 53421	85
Thermal conductivity	W/mK	DIN 53432	0.225

Material data from our raw materials supplier. * Material currently used by us. We also use other material systems, depending on the requirements.